

Airwork's solenoid valves combine big resistance, reliability and versatility of assemblage; the VY series can be assembled in several ways: In-line, on panel, on multiple bases, on manifolds and on cylinders.

Available size are 1/8, 1/4 and 1/2, the available functions are 3/2, 5/2 e 5/3.

La série des électro distributeurs à raccordement direct série VY d'AIRWORK a des caractéristiques multiples de robustesse, de fiabilité et de montage. En ligne, sur embase multiple, assemblée et directement sur le vérin. Il est disponible en taille 1/8, 1/4 et 1/2 ainsi qu'en fonction 3/2, 5/2 et 5/3.

La serie di elettrovalvole serie VY di Airwork, possiedono caratteristiche di grande robustezza, affidabilità e versatilità di montaggio, infatti la serie VY si possono montare in diversi modi: in linea, a parete, su base multipla, su collettori e persino direttamente su cilindro. Sono disponibili in tre taglie 1/8, 1/4 e 1/2 nelle funzioni 3/2, 5/2 e 5/3.

TECHNICAL DATA / DONNÉES TECHNIQUES / DATI TECNICI

	1/8	1/4	1/2
Flow rate 6 bar Δp 1 bar / Débit à 6 bar Δp 1 bar / Portata a 6 bar Δp 1 bar	550 Nl/min	1100 Nl/min	4600 Nl/min
Nominal orifice / Diamètre nominal / Diametro nominale	5mm	7.5mm	13mm
Response times mono-stable / Temps réponse monostable / Tempi risposta monostabile	TRA 15ms / TRR 35ms	TRA 19ms / TRR 45ms	TRA 39ms / TRR 60ms
Response times bi-stable / Temps réponse bistable / Tempi risposta bistabile	TRA 20ms / TRR 20ms	TRA 22ms / TRR 22ms	TRA 90ms / TRR 90ms
Coils tension / Tension bobine / Tensione bobine	12VDC - 24VDC - 24VAC - 110VAC - 220VAC 50/60Hz		
Pressure range / Pression d'utilisation / Pressione di esercizio	<ul style="list-style-type: none"> monostable / monostable / monostabile 2.5 ÷ 10 bar bistable / bistable / bistabile 1 ÷ 10 bar separate power supply / alimentation séparée / alimentazione separata vacuum ÷ 10 bar 		
Temperature range / Température d'utilisation / Temperatura di esercizio	-10°C ÷ +60°C		
Voltage tolerance / Tolérance / Tolleranza tensione	± 10%		
Power consumption / Absorbition / Assorbimento	2W (DC) - 3VA (AC)		
Isulation / Classe / Isolamento	classe F		

ORDERING CODE / CODIFICATION / CHIAVE DI CODIFICA

VY85ELM00-T

VERSION / VERSION / VERSIONE

T= Standard
EX= Atex

FUNCTION / FUNCTION / FUNZIONE

00= 5/2
NC= Normally closed / Normalement fermé / Normalmente chiuso
NA= Normally open / Normalement ouvert / Normalmente aperto
CC= Closed centers / Centres fermés / Centri chiusi
CA= Open centers / Centres ouverts / Centri aperti
CP= Pressure centers / Centre pression / Centri n pressione

FUNCTION / FUNCTION / FUNZIONE

M= Monostable / Monostable / Monostabile
B= Bistable / Bistable / Bistabile

PILOTS / COMMANDES / COMANDI

EL= Solenoid / Électrique / Elettrico
EA= Electric with separate power supply / Électrique avec alimentation séparée / Elettrico con alimentazione separata

FUNCTION / FUNCTION / FUNZIONE

3= 3/2
5= 5/2
6= 5/3

AIR PORTS / CONNEXIONS D'AIR / ATTACCHI ARIA

8= 1/8
4= 1/4
2= 1/2



On request Atex version:
Sur demande version Atex:
Su richiesta versione Atex:
II 2G Ex h IIB T5 Gb
II 2D Ex h IIB T100°C Gc

THE KEY POINTS / LES POINTS CLES / PUNTI DI FORZA

Spool seals high quality to guarantee operation under all conditions and temperatures.

Joint de tiroir de haute qualité garantissent un très bon fonctionnement dans des conditions de températures élevées.

Guarnizioni spola ad altissima prestazione per garantire un funzionamento perfetto in tutte le condizioni e temperatura.

Manual operating in steel nickel-plated unlike the plastic component this one provides strength and precision even after many interventions.

Commande manuelle en acier nickelé à la différence du composant en plastique.

Elle présente une résistance et fournit une précision même après de nombreuses interventions.

L'intervento manuale in acciaio nichelato a differenza di componenti in plastica, fornisce la resistenza e precisione anche dopo molti interventi.

Valve's body is very important and it is realized from a full bar, turned and milled on CNC machines, then anodized to give more strength to it and painted to cover any possible outside imperfection.

Le corps de la vanne est très important . Réalisé à partir d'une barre, tournée , fraisée sur des machines CNC, puis anodisé pour donner plus de force puis peint.

Il corpo valvola è molto importante ed è realizzato da una barra piena, tornito e fresato su macchine a controllo numerico, quindi anodizzato per dare più durezza alla superficie e poi verniciato

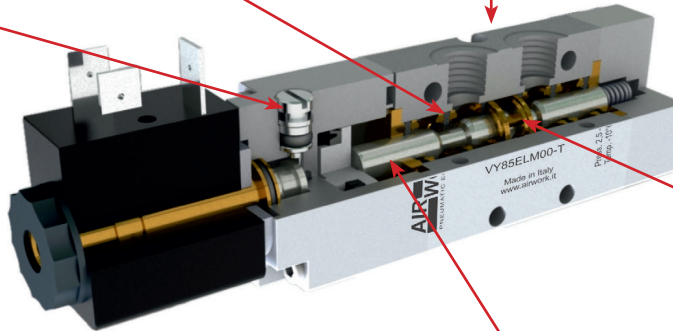

Spacer cages in brass.

Unlike the plastic, brass ones do not deform with the change of temperature, giving more stability to the seals and avoiding any possible backlash.

Cages d'espacement en laiton. Contrairement à la matière plastique, les cuivres ne se déforment pas avec le changement de température, ce qui donne une plus grande stabilité des joints et évite toute réaction possible.

Le gabbie distanziali in ottone a differenza della plastica, non si deformano con il variare della temperatura dando maggiore stabilità alle guarnizioni ed evitando ogni possibile reazione.

Other strengths / Autres points forts / Altri punti di forza

- Guaranteed for 50 million cycles / **Garanti pour 50 millions de cycles** / *Garantita per 50 milioni di cicli.*
- Manifolds mounting / **Collecteurs de montage** / *Collettori di montaggio.*
- Wall mounting / **Montage mural** / *Montaggio a parete.*
- Cylinder mounting / **Montage sur vérin** / *Montaggio su cilindro.*
- Strong and stylish packaging / **Emballage solide et élégant** / *Imballaggio solido ed elegante.*

Machined aluminum spool precisely finished with chemical nickel treatment: the result is very low roughness and a longer duration of seals

Tiroir en aluminium usiné avec finitions au traitement de nickel chimique: le résultat est une très faible rugosité et une plus longue durée de vie des joints.

Spola in alluminio lavorata con finitura di precisione con trattamento di nichelatura chimica: il risultato è una rugosità molto bassa e una maggiore durata delle guarnizioni spola.

COMPONENTS / COMPOSANTS / COMPONENTI

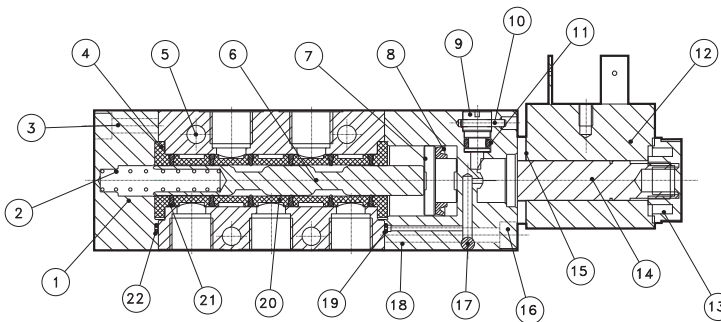

N.	DESCRIPTION / DESCRIPTION / DESCRIZIONE	MATERIAL / MATIÈRE / MATERIALE
1	spring bottom / fond ressort / <i>fondello molla</i>	plastic and aluminium / plastique et aluminium / <i>plastica e alluminio</i>
2	spring / ressort / <i>molla</i>	C98 steel / acier C98 / <i>acciaio C98</i>
3	screw / vis / <i>vite</i>	steel / acier / <i>acciaio</i>
4	spool distance / tiroir distanciel / <i>distanziale spola</i>	brass / laiton / <i>ottone</i>
5	body valve / corps valve / <i>corpo valvola</i>	aluminium / aluminium / <i>alluminio</i>
6	spool / tiroir / <i>spola</i>	aluminium / aluminium / <i>alluminio</i>
7	piston / piston / <i>pistone</i>	Delring 500
8	piston seal / joint piston / <i>guarnizione pistone</i>	NBR
9	manual operating / commande manuelle / <i>intervento manuale</i>	brass / laiton / <i>ottone</i>
10	plug / rotor / <i>spina</i>	steel / acier / <i>acciaio</i>
11	o-ring / joint torique	NBR
12	coil / bobine / <i>bobina</i>	
13	nut M8x0,75 / écrou M8x0,75 / <i>dado M8x0,75</i>	plastic / plastique / <i>plastica</i>
14	tube / tube / <i>tubetto</i>	brass / laiton / <i>ottone</i>
15	tube plaque / tube / <i>piastrella tubetto</i>	steel / acier / <i>acciaio</i>
16	screw / vis / <i>vite</i>	steel / acier / <i>acciaio</i>
17	sphere / sphère / <i>sfera</i>	steel / acier / <i>acciaio</i>
18	electric bottom / fond electrique / <i>fondello elettrico</i>	plastic and aluminium / plastique et aluminium / <i>plastica e alluminio</i>
19	o-ring / joint torique	NBR
20	cage distance / cage distance / <i>distanziale gabbia</i>	brass / laiton / <i>ottone</i>
21	spool seal / joint du tiroir / <i>guarnizioni spola</i>	NBR
22	o-ring / joint torique	NBR

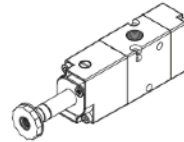
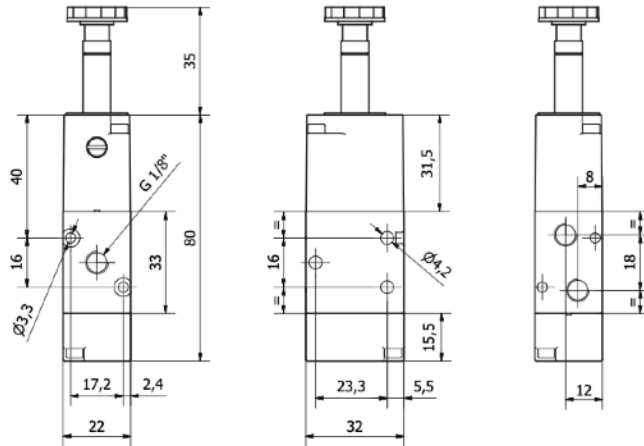

1/8 - 3/2 NC monostable
1/8 - 3/2 NF monostable
1/8 - 3/2 NC monostabile

CODE
VY83ELMNC-T

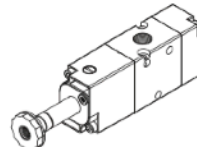
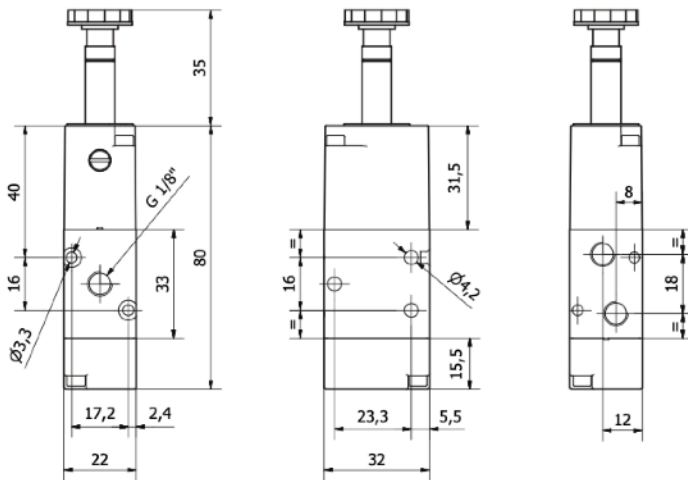

1/8 - 3/2 NO monostable
1/8 - 3/2 NO monostable
1/8 - 3/2 NA monostabile

CODE
VY83ELMNA-T

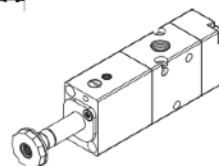
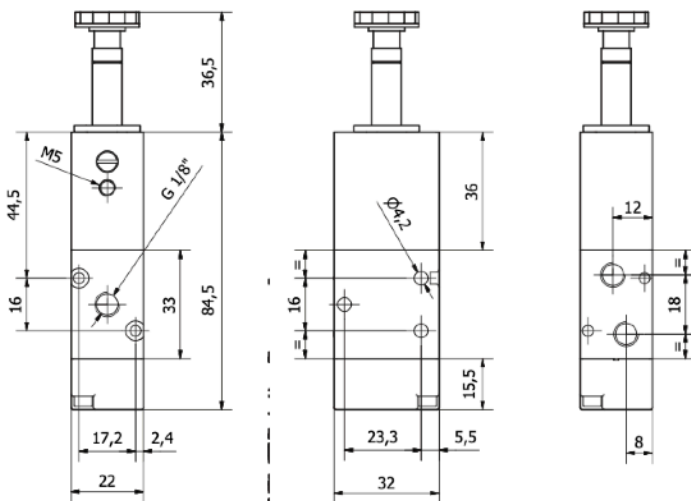
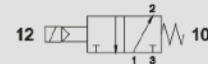

1/8 - 3/2 NC monostable separate air supply
1/8 - 3/2 NF monostable alimentation séparée
1/8 - 3/2 NC monostabile alimentazione separata

CODE
VY83EAMNC-T

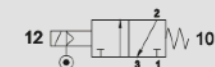

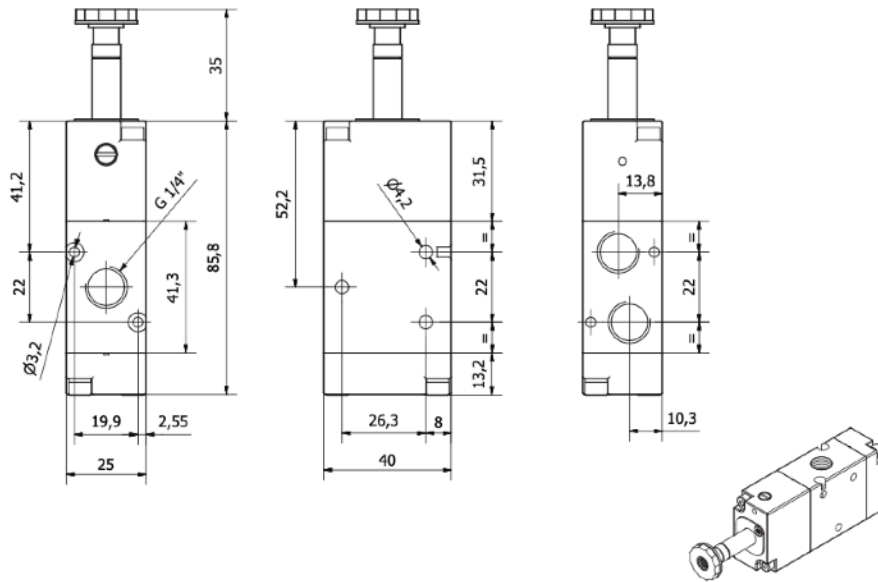

1/4 - 3/2 NC monostable
1/4 - 3/2 NF monostable
1/4 - 3/2 NC monostabile

CODE
VY43ELMNC-T

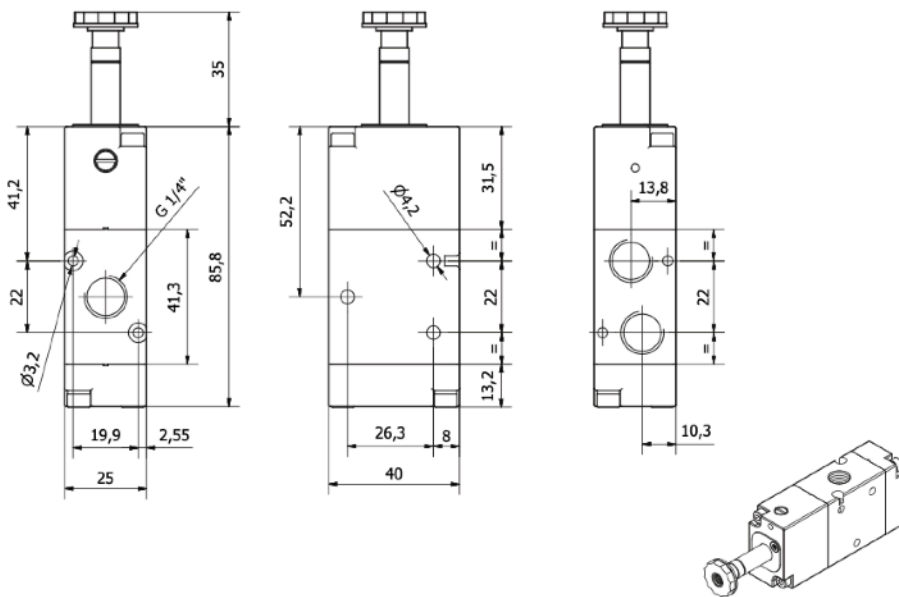
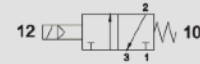

1/4 - 3/2 NO monostable
1/4 - 3/2 NO monostable
1/4 - 3/2 NA monostabile

CODE
VY43ELMNA-T

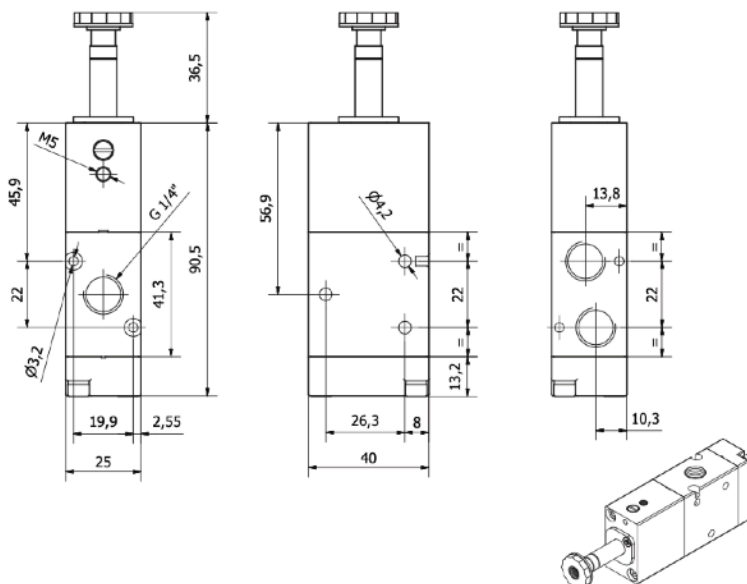
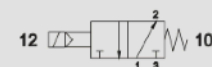

1/4 - 3/2 NC monostable separate air supply
1/4 - 3/2 NF monostable alimentation séparée
1/4 - 3/2 NC monostabile alimentazione separata

CODE
VY43EAMNC-T



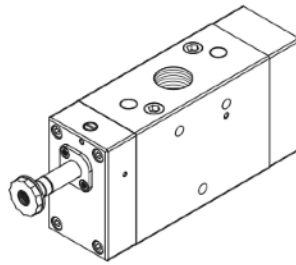
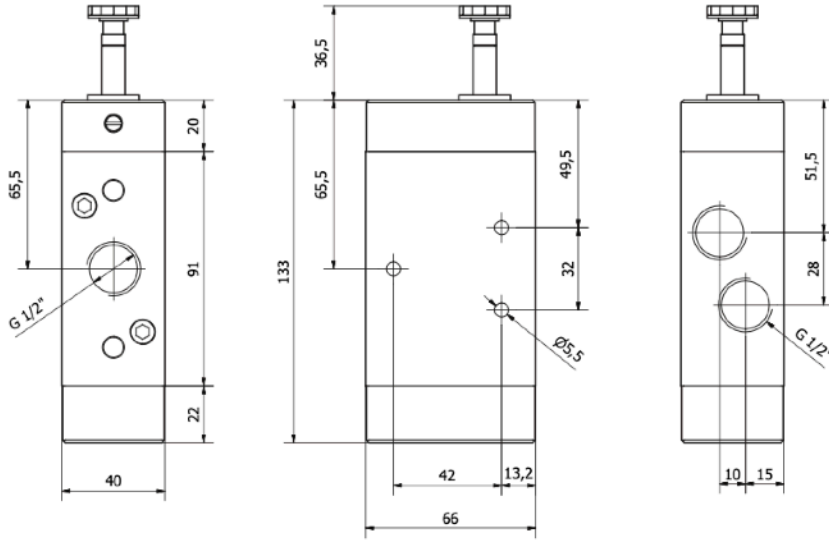

1/2 - 3/2 NC monostable
1/2 - 3/2 NF monostable
1/2 - 3/2 NC monostabile

CODE
VY23ELMNC-T

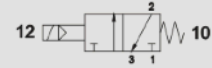

1/2 - 3/2 NO monostable
1/2 - 3/2 NO monostable
1/2 - 3/2 NA monostabile

CODE
VY23ELMNA-T

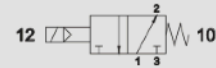

1/2 - 3/2 NC monostable separate air supply
1/2 - 3/2 NF monostable alimentation séparée
1/2 - 3/2 NC monostabile alimentazione separata

CODE
VY23EAMNC-T

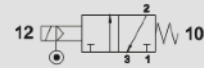

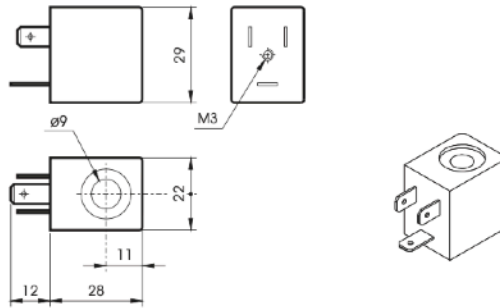

COILS 22mm / BOBINE 22mm / BOBINE 22mm

POWER / ABSORPTION / ASSORBIMENTO

CODE	Tension Tension Tensione	Rated Résistance a regime	Inrush De sortie di spunto
BO4011012	12 VDC	3W	
BO4011024	24 VDC	3W	
BO4012024	24 VAC	5VA	7,5VA
BO4012110	110 VAC	5VA	7,5VA
BO4012220	220 VAC	5VA	7,5VA

TECHNICAL SPECIFICATIONS / CARACTERISTIQUES
TECHNIQUES / CARATTERISTICHE TECNICHE

Tension tolerance / Tolérance / Tolleranza di tensione	±10%
Protection with connector / Protection avec conn. / Protezione con connettore	IP65
Temperature range / Température d'utilisation / Temperatura di utilizzo	-40°C + 50°C
Duty cycle / Temps d'enclenchement / Inserimento	ED 100%

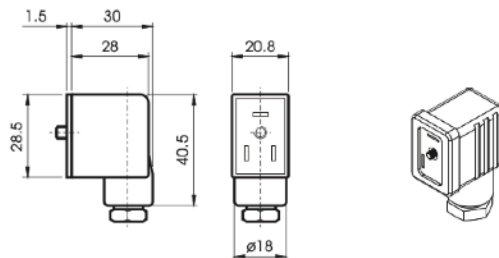

CONNECTORS / CONNECTEUR / CONNETTORI

CODE	
AR40696	STANDARD
VX0014	LED 24V
VX0015	LED 110V
VX0016	LED 220V
VX0017	LED+VDR 24V
VX0018	LED+VDR 110V
VX0019	LED+VDR 220V

ATEX CONNECTORS / CONNECTEUR ATEX /
CONNETTORI ATEX

CODE	
AR40696-EX	ATEX

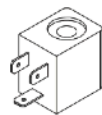

II 3G Ex nA IIC T5 Gc x
II 3D Ex tc IIC 95°C Dc x

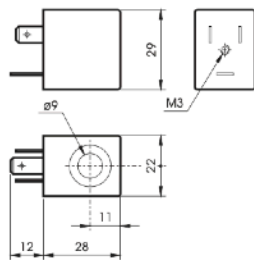

ATEX COILS 22mm / BOBINE ATEX 22mm / BOBINE ATEX 22mm

POWER / ABSORPTION / ASSORBIMENTO

CODE	Tension Tension Tensione	Rated Résistance a regime	Inrush De sortie di spunto
BO4011024-EX	24 VDC	3W	
BO4012024-EX	24 VAC	5VA	7,5VA
BO4012110-EX	110 VAC	5VA	7,5VA
BO4012220-EX	220 VAC	5VA	7,5VA

TECHNICAL SPECIFICATIONS / CARACTERISTIQUES
CARATTERISTICHE TECNICHE

Tension tolerance / Tolérance / Tolleranza di tensione	±10%
Protection with connector / Protection avec connecteur / Protezione con connettore	IP66
Temperature range / Température d'utilisation / Temperatura di utilizzo	-5°C / + 50°C
Duty cycle / Temps d'enclenchement / Inserimento	ED 100%

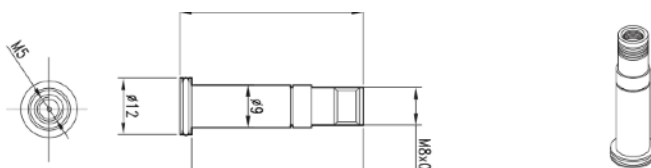

ELECTROPILOTE
ELETTROPILOTA

CODE	
EP43603	

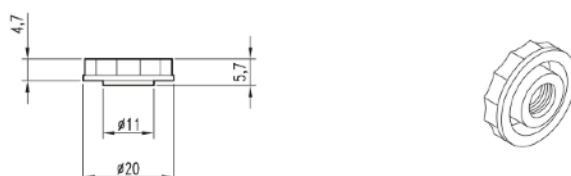

NUT
ECROU
DADO

CODE	
DA42937	