



## Dampness-proof cap for Kit 2 way

R452714-B

÷

R452714-U

### FEATURES:

The Kit 2 way dampness-proof allow to have coils with protection degree IP 67.

Cables and suitable connector .

CODE:	COIL COMPATIBLE:
R452714-B	serie "B" (BDF-BDS-BDV)
R452714-G	serie "G" (GDH-GDV)
R452714-S	serie "S" (SDH)



CODE:	COIL COMPATIBLE:
R452714-U	serie "U" (UDV)

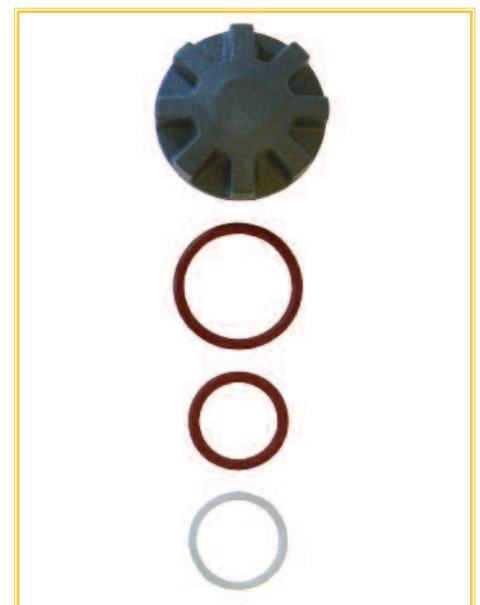

### Note

Available on request and with minimum quantities.

The "ODE" reserves the right to carry out technical and aesthetic modifications without prior notification.

KIT FOR COIL TYPE: BDS-BDV-BDF  
Code: R452714-B

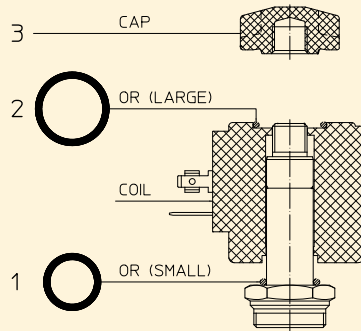

Assemblage sequence: 1 - coil - 2 - 3

KIT FOR COIL TYPE: GDH-GDV  
Code: R452714-G

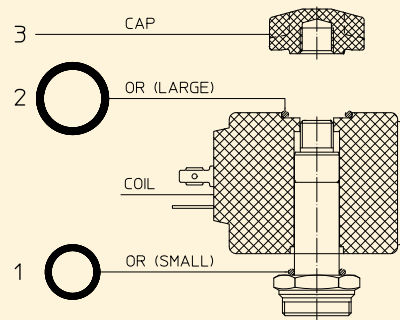

Assemblage sequence: 1 - coil - 2 - 3

KIT FOR COIL TYPE: SDH  
Code: R452714-S

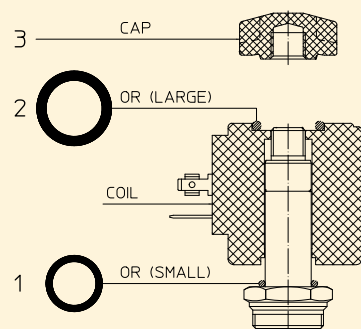

Assemblage sequence: 1 - coil - 2 - 3

KIT FOR COIL TYPE: UDV  
Code: R452714-U

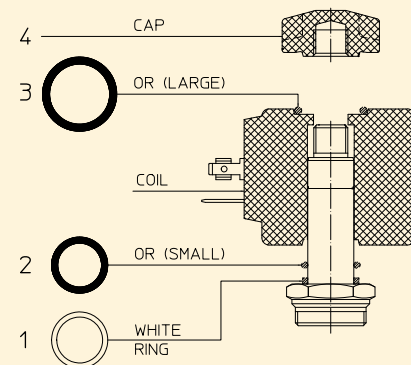

Assemblage sequence: 1 - coil - 2 - 3 - 4