

ø1/2" Gas Outside casing ground

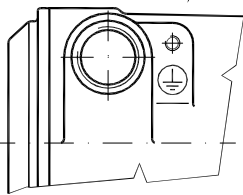

Die-cast aluminium casing UNI5076
 Standard AC3 4 vane Stainless Steel screw.
 Wiring with antivibrations cable terminals (Faston).
 Stainless Steel flange.
 Maximum dimension hole on counterflange = ø105.

4 ø7 holes

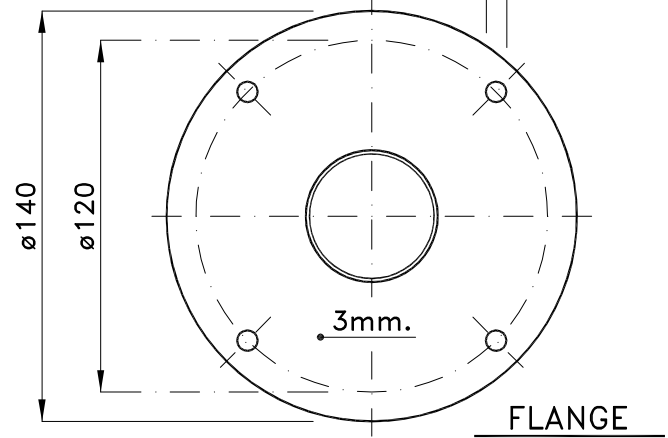

Inside casing ground

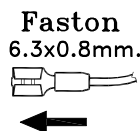
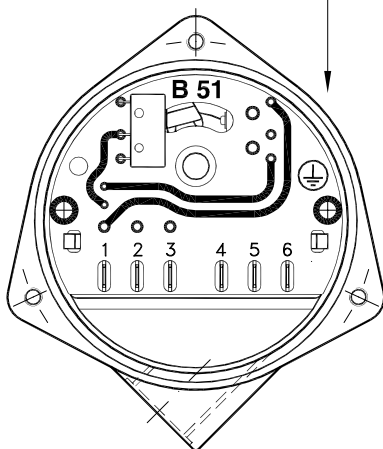

- WIRING**
- 1 - Common power supply
 - 2 - Power supply 110 Va.c. 50/60 Hz
 - 3 - Power supply 220 Va.c. 50/60 Hz
 - 4 - NC contact 5A/250 Va.c.
 - 5 - Common contacts
 - 6 - NO contact 5A/250 Va.c.
- Electric motor draw 4 W
 Ambient temperature range -20 to +80 °C
 Weight : 1.200 Kg
 On request power supply at 24/48 Va.c. 50/60Hz
 And also at 24 Vd.c.
 Maximum operational pressure 1.1 bar

Certificate number TÜV 03 ATEX 2374 X
 Marking: II 1/2D T200°C IP65

IP65 Protection
Heat resistant up to 200°C



SMALL-SIZED BLADED LEVEL GAUGE PARTICULARLY SUITABLE FOR USE ON SMALL TANKS OR BATCHING CELLS.

PARTS IN CONTACT WITH THE PRODUCTS ARE MADE OF STAINLESS STEEL