

Die-cast aluminium casing UNI5076
 Standard AC1 1 vane NYLON screw.
 Wiring with antivibrations cable terminals (Faston).

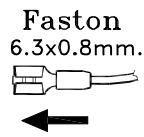
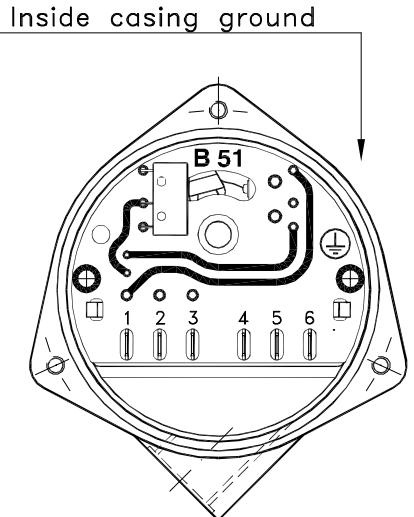

WIRING

- 1 - Common power supply
- 2 - Power supply 110 Va.c. 50/60 Hz
- 3 - Power supply 220 Va.c. 50/60 Hz
- 4 - NC contact 5A/250 Va.c.
- 5 - Common contacts
- 6 - NO contact 5A/250 Va.c.

Electric motor draw 4 W

Ambient temperature range -20 to +70 °C

Weight : 1.200 Kg

On request power supply at 24/48 Va.c. 50/60Hz - And also at 24 Vd.c.

IP65 Protection

Maximum operational pressure 1.1 bar

SMALL-SIZED BLADED LEVEL GAUGE PARTICULARLY SUITABLE FOR USE ON SMALL TANKS OR BATCHING CELLS.

STANDARD ASSEMBLY WITH 1 1/2 GAS THREADED NUT

Certificate number TÜV 03 ATEX 2374 X
 Marking: II 1/2D T85°C IP65



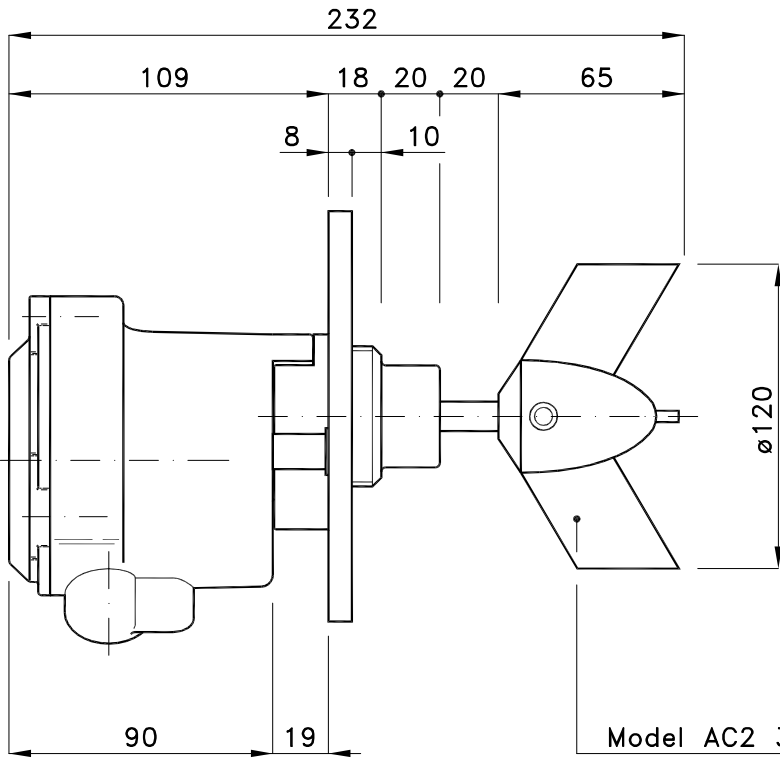

Die-casting aluminium flange.

Make in two versions: $\varnothing 140$ and $\varnothing 105$ mm.

Maximum dimension hole on counterflange:
for flange $\varnothing 140 = \varnothing 105$
for flange $\varnothing 105 = \varnothing 75$

Existing space between flange and level gauge casing allows the M6x12 bolts assemblage.

Flange can be installed at a later date.

The flange is fixed on level gauge casing by two M6 screws.

Model AC2 3 vanes NYLON screw

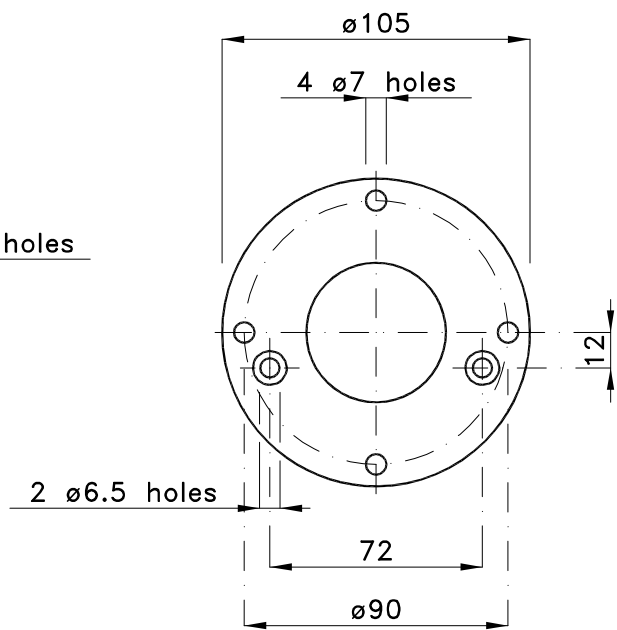
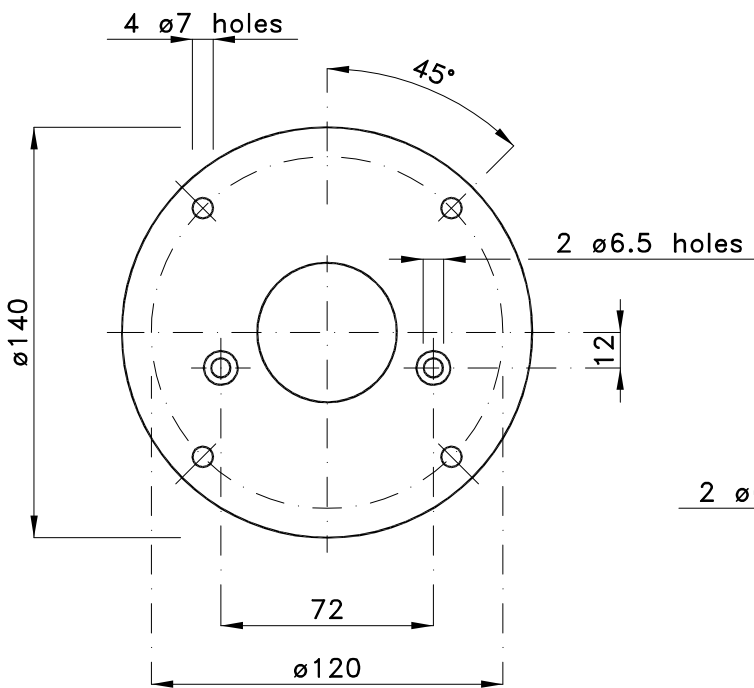

Level gauge can be delivered with extension, with or without protection, the length is defined by the buyer during the order.

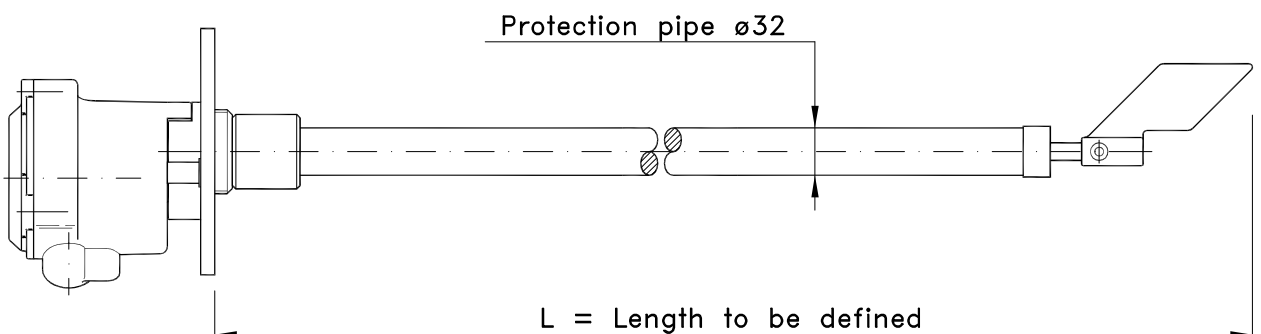

The extension can be installed at a later date