

PARTS IN CONTACT WITH THE PRODUCTS ARE MADE OF STAINLESS STEEL

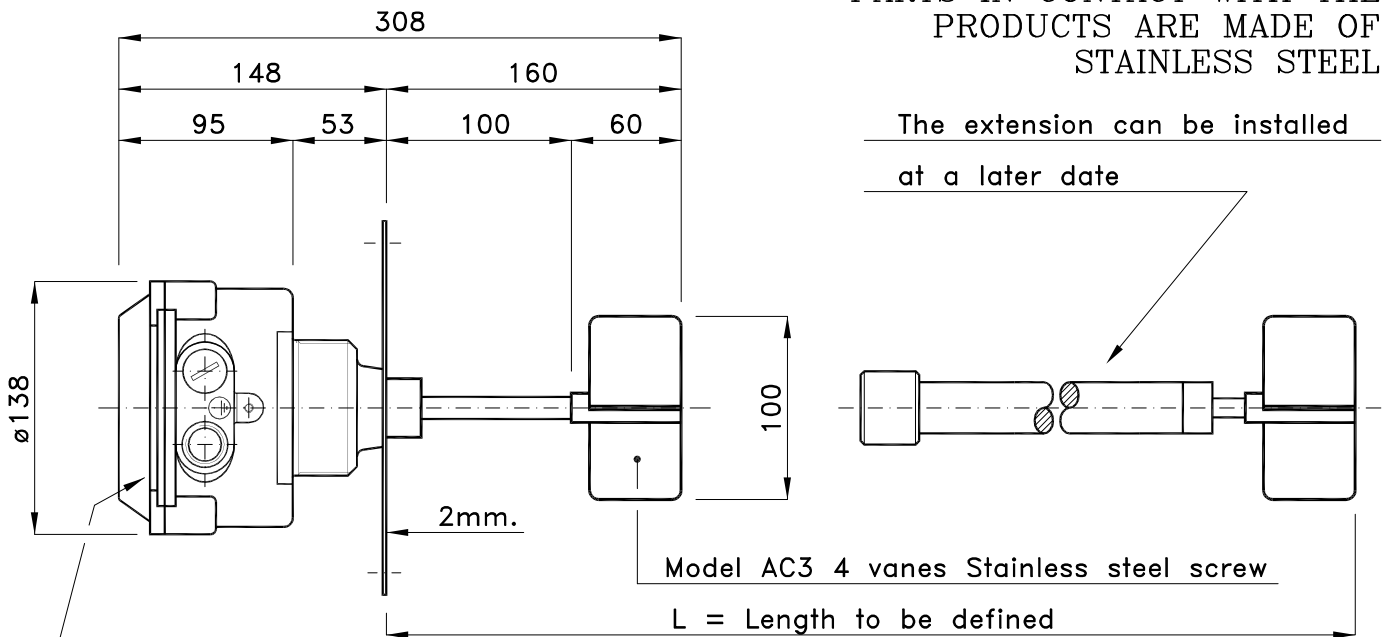

Cable inlet $\frac{1}{2}$ " Gas - double horizontal on right side

6 equidistant $\phi 6.5$ holes

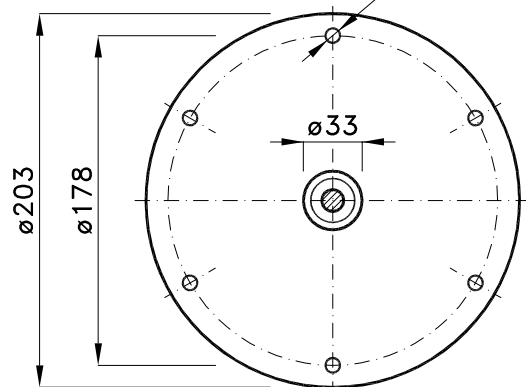
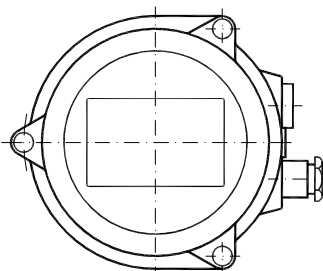

IP65 Protection

WIRING

- 1 - Common power supply
- 2 - Power supply 110 Va.c. 50/60 Hz
- 3 - Power supply 220 Va.c. 50/60 Hz
- 6 - NC contact 10A/250 Va.c.
- 7 - Common contacts
- 8 - NO contact 10A/250 Va.c.

Ambient temperature range -20 to $+70$ °C

Weight : 2.300 Kg

On request power supply at 24/48 Va.c. 50/60 Hz or power supply at 24 Vd.c.

Electric motor draw 4 W

Maximum operational pressure 1.1 bar

Certificate number TÜV 03 ATEX 2374 X
Marking: II 1/2D T85°C IP65

