

CA & RCA
20 DD

GOYEN

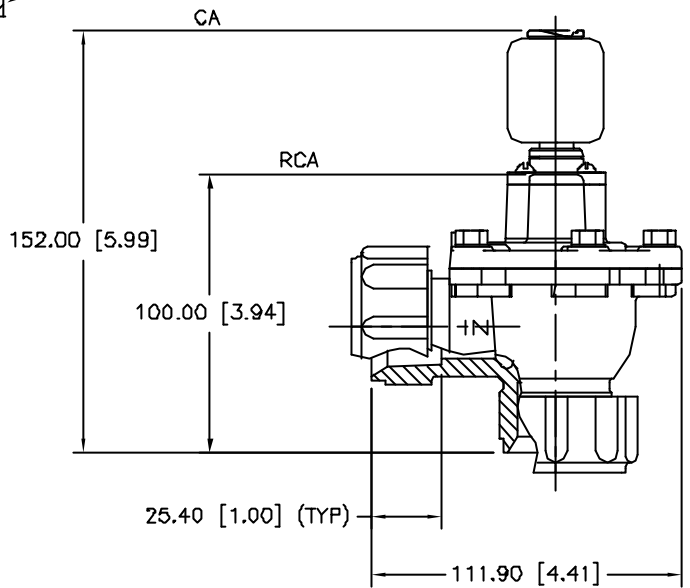
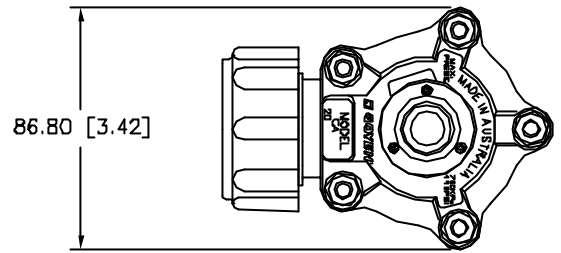
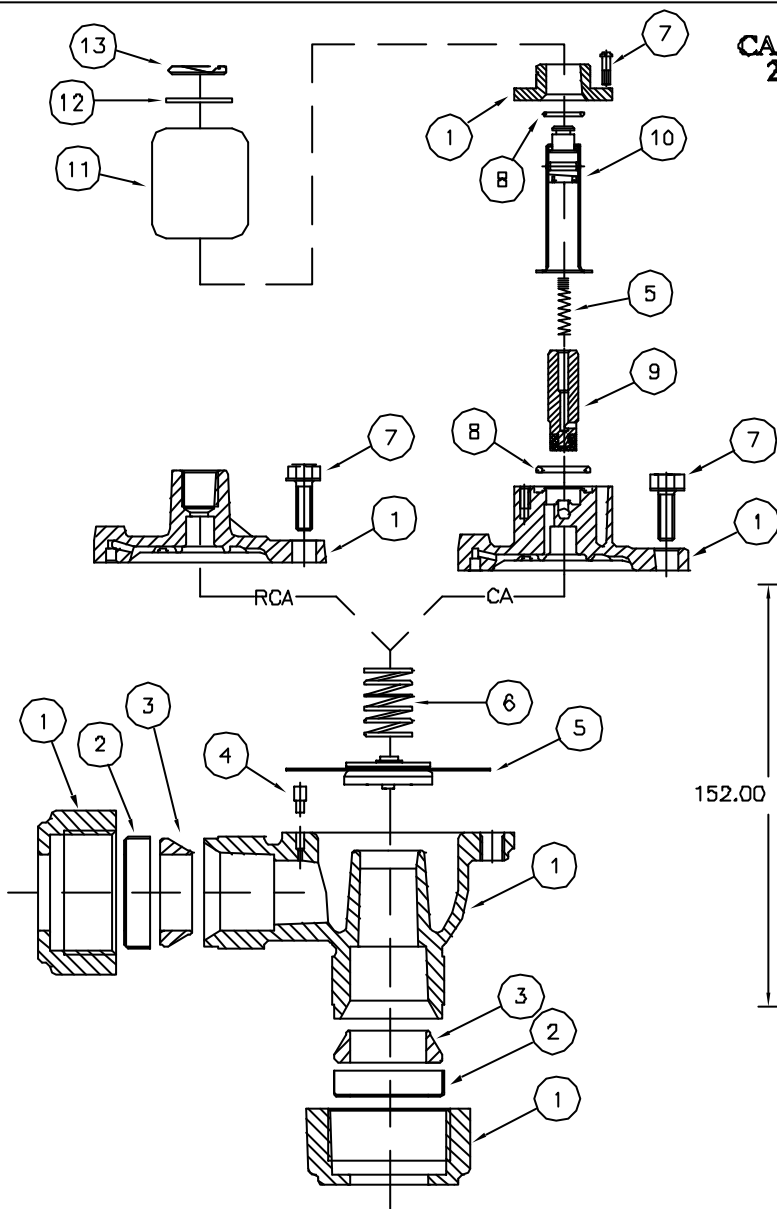

MECHANICAL DETAILS

No	DESCRIPTION	STANDARD MATERIAL	PORT OPTIONS	HIGH TEMP MATERIALS	KIT No STANDARD	KIT No HIGH TEMP
1	BODY,COVER,NUT	ALUM DIE CAST CA313	3/4" PIPE	AS STANDARD	-	-
2	SEAL RETAINER	M.S GALVABOND	N/A	AS STANDARD	K2008	K2009
3	SEAL	BUNA N RUBBER	N/A	VITON	K2008	K2009
4	BLEED PIN	SPRUNG STEEL	N/A	AS STANDARD	-	-
5	DIAPHRAGM ASS'Y	BUNA N / NYLON	N/A	VITON	K2000	K2007
6	SPRING	304 STAINLESS STEEL	N/A	AS STANDARD	-	-
7	SCREW	304 STAINLESS STEEL	N/A	AS STANDARD	-	-
8	O' RING	BUNA N / NITRILE	N/A	VITON	-	-
9	PLUNGER ASS'Y	430 FR ST/STL	N/A	AS STANDARD	K0380	-
10	FERRULE/IRON TOP ASS'Y	305 STAINLESS STEEL	N/A	AS STANDARD	K0380	-
11	COILS	130° RATED NYLON ENCAPSULATION	QD -1/2 NPSC -M20x1.5	N/A	QR-K030-K0309 QD(M)-K0310-K0319 QD(N)-K0320-K0329	N/A
12	WASHER	PRESSED ALUMINIUM	N/A	AS STANDARD	-	-
13	CLIP	MECH PLATED STEEL	N/A	AS STANDARD	-	-

ELECTRICAL DETAILS

COIL VOLTAGE	200/240 VAC, 100/120 VAC, 24 VAC, 24 VDC, 12 VDC
COIL CONNECTION	QR - DIN CONNECTION QD CONDUIT ENTRY

WEIGHTS

UNIT WEIGHT	RCA = 0.610 Kg CA = 0.820 Kg
-------------	------------------------------

DOC No	CAS_DG_20DD
REVISION No	2
ISSUE DATE	17.7.2002