



Coils

INDEX

APPROVALS

ALPHABETIC SERIES

POWER	5 W - 10 VA	7 W - 11,5 VA 12,5 VA - 13,5 VA	8 W - 14,5 VA	10 W	11 W - 15 VA 16 VA - 17 VA	12 W - 22 VA ED 50%	12 W - 23 VA 25 VA	14 W - 23 VA 26 VA - 27 VA	CE	Ex	UL	UL	VDE	UL
Width	22 mm	22 mm	30 mm	22 mm	30 mm	28 mm	36 mm	52 mm						
BDA			CONNECTOR EN 175301-803						X					
BDF					CONNECTOR EN 175301-803				X			(2)		
BDV					CONNECTOR EN 175301-803				X					(1)
BSA			CABLES 100 cm						X					
BVA			CABLES 50 cm						X					
GDH								CONNECTOR EN 175301-803	X					
GDV								CONNECTOR EN 175301-803	X					(1)
ICA						FASTON DIN 46244								
LBA	CONNECTOR EN 175301-803								X					
LBF	CONNECTOR EN 175301-803								X		(3)			
LBV		CONNECTOR EN 175301-803		CONNECTOR EN 175301-803					X		(3)	(2)	(4)	(1)
TNA	See coils list								X	(5)				
UDA							CONNECTOR EN 175301-803		X					
UDV							CONNECTOR EN 175301-803		X			(2)		

ELECTRICAL CONNECTION

- (1) Available also with UL, CSA, VDE approval.
- (2) For some voltages UL, CSA approval available.
- (3) For some voltages UL approval available.

- (4) For some voltages VDE approval available.
- (5) Approval Ex mb II T 4

The "ODE" reserves the right to carry out technical and aesthetic modifications without prior notification.

Coils codes

DIMENSIONS:

- B** Width 30 - tube Ø 13
- G** Width 52 - tube Ø 13
- I** Width 28 - tube Ø 10
- L** Width 22 - tube Ø 10
- T** Width 36 - tube Ø 14,5
- U** Width 36 - tube Ø 13

ELECTRICAL CONNECTIONS:

- B** connector EN 175301-803 whellbase 11
- C** 2 faston DIN 46244
- D** connector EN 175301-803 paragraph 5.3.1
- N** 3 cables cm 300
- S** 2 cables cm 100
- V** 2 cables cm 50

MOLDING MATERIAL:

- A** PA - Black polyamide - class F (155°C)
- F** PPS - Black polyphenylensulphide - class H (180°C)
- H** EP - Black epoxy resin - class H (180°C)
- V** PET - Black Polyethylene - class H (180°C)

B D A 0 8 2 3 0 A S

APPROVALS:

- A** Explosion-proof
- S** Without approval
- U** UL approval
- V** VDE approval
- W** UL, CSA approval
- Y** UL, CSA, VDE approval

FREQUENCY:

- A** 50 Hz ED 100%
- B** 60 Hz ED 100%
- C** D.C. ED 100%
- D** 50/60 Hz ED 100%
- E** 50 Hz ED 50%
- H** D.C. ED 50%

POWER:

- 4X** 7,2 VA
- 0 5** 5 W - 7W
7,7 VA - 9,24 VA
10 VA - 11,5 VA
12,5 VA - 13,5VA
- 5X** 9,13 VA
- 0 8** 8 W - 10W -
11W - 14,5 VA -
15 VA - 16 VA -
17 VA
- 10** 10,1 W
- 1 2** 12 W - 22 VA
23 VA - 25 VA
- 1 4** 14 W - 23 VA
26 VA - 27 VA

VOLTAGES:

- 0 1 2** 12 V
- 0 2 4** 24 V
- 1 1 0** 110 V
- 1 1 2** 110 -120 V
- 2 2 0** 220 V
- 2 2 3** 220-230 V
- 2 2 4** 220-240 V
- 2 3 0** 230 V
- 3 8 0** 380 V

NOMINAL VOLTAGE TOLERANCES:

- DC + 10% -5%
- AC + 10% -15%



COILS 36 mm x Ø 13 mm

UDA12024AS
÷
UDV12230DW

COIL **UDA** Molding material: PA - Black polyamide - class F (155°C)
UDV Molding material: PET - Black Polyethylene - class H (180°C)

Winding: In class H

Electrical connections: With connector EN 175301-803 paragraph 5.3.1
Protection degree IP 65 EN 60529 (DIN 40050)

MOULDING AND BOBBIN ARE MADE BY 100% VIRGIN MATERIAL

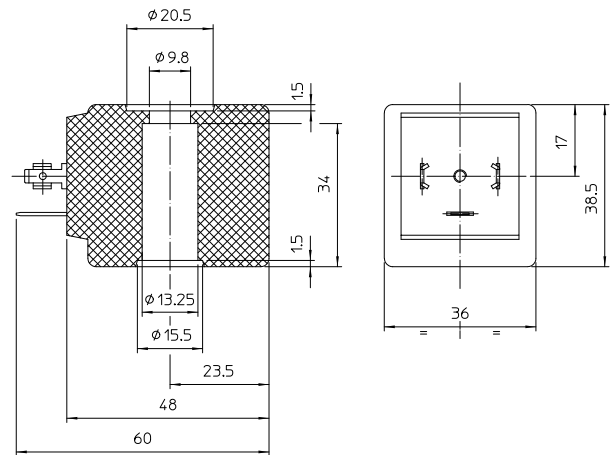

MATERIAL ON STOCK:

Code	Power	Voltages/Frequency	ED	Approvals
UDA12024AS	23 VA	24 ~ 50	100%	CE
UDA12024CS	12 W	24 ---	100%	CE
UDA12110DS	23 VA	110 ~ 50/60	100%	CE
UDA12230AS	23 VA	230 ~ 50	100%	CE
UDV12112DW	23 VA	110/120 ~ 50/60	100%	CE - UL - CSA
UDV12230DW	25 VA	230 ~ 50/60	100%	CE - UL - CSA

NOMINAL VOLTAGES DC + 10% - 5%
TOLERANCES: AC +10% - 15%

Other voltages and power absorptions available on demand and for quantities.

The "ODE" reserves the right to carry out technical and aesthetic modifications without prior notification.